

TEK-BC TEKNEK BOARD CLEANERS

teknek

An ITW Company



TEK-BC TEKNEK BOARD CLEANERS

The Tek-BC range is the future in “Low Static – Low Stress” board cleaning for today’s SMT industry. Driven by the Teknek 2.0 philosophy, these multi-functional products are fully Industry 4.0 compatible. Known throughout the world for our cleaning technology, these ground-breaking products offer your process so much more.

SPECIFICATION

	Tek-BC-20	Tek-BC-20C
Product	Single Side - Board Cleaner	Single Side - Board Cleaner
Cleaning Width	40 – 400mm	40 – 400mm
Operating Modes	Clean / By-Pass	Clean / By-Pass
Roller Options	SMT NT™ / Nanoclean	SMT NT™ / Nanoclean
Adhesive Options	GAR / AREF	GAR / AREF
Board Hold Conveyor	Standard	Not Available
Process Speed	2 – 22m/min	2 – 22m/min
Pass Height	900 ± 50mm	900 ± 50mm
Mains Power	110 – 240vAC	110 – 240vAC
Air Supply	5 – 7 bar “OIL FREE AIR”	5 – 7 bar “OIL FREE AIR”

Note: Low Static Cleaning, ESD Compliant requires SMT NT™ & GAR

PRODUCT COMPLIANCE

	Tek-BC-20 & 20C
Machine	ANSI / ESD s6.1 – 2014 & IEC 61340-5-1-2016
All Cleaning Rollers	ISO 6122 CLASS A
SMT NT™ / NANOCLEEN	ANSI / ESD s20.20 - 2014
All Adhesives	FINAT



TEKNEK APPs



Board Monitor

- The right Contact / The right Cleaning
- Minimum pressure / Reduce Board Stress
- Accuracy to 0.2mm
- Double Board Feed Detection



Motor Monitor

- Predictable Maintenance
- Realtime Motor Status
- Can Bus Control System



Belt Monitor

- Predictable Maintenance
- Instant Operator Alert
- Belt Control Tensioning "Longer Life"



Internal Camera

- Internally Mounted Camera
- Realtime Display
- No Windows – No ESD Issues



Comms - General

- SMEMA
- Hermes
- MES "APOLLO"



Static Monitor

- Static Monitored to Customers Specification
- Optional Internal Feature – Tek-BC-20
- Optional External Feature – Tek-BC-20C



Brush & Vacuum

- Optional internal Feature – "Heavy Contamination"
- Counter Rotating ESD Brush
- Optional External Extraction "BOFA"



TEK-BC TEKNEK BOARD CLEANERS



An ITW Company

TECHNICAL SPECIFICATION

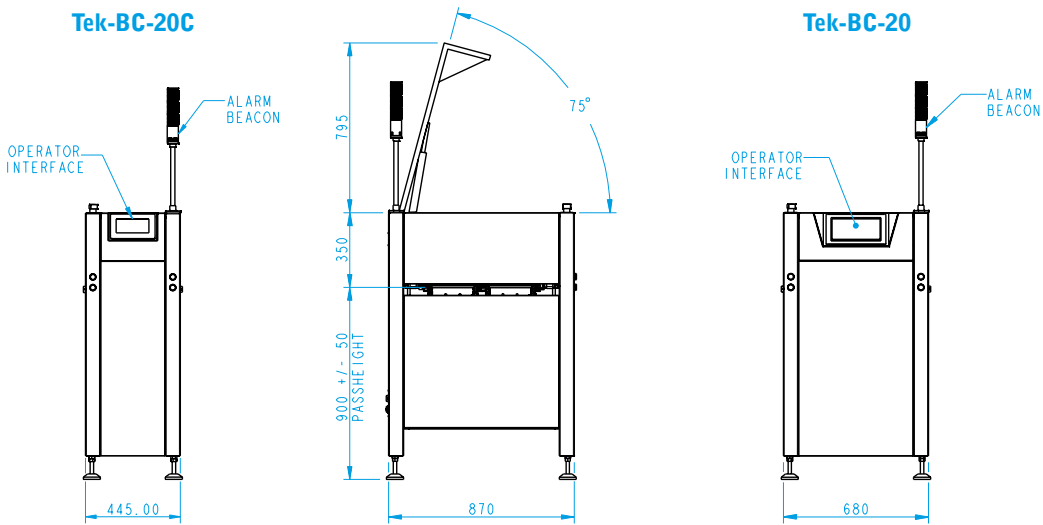

CAPABILITY

Tek-BC-20 Clean & By-Pass	Min – Max Length	50mm – 350mm
	Min – Max Width	40mm – 400mm
	Min – Max Thickness	0.6mm – 3.2mm
Tek-BC-20 Board Hold	Min – Max Length	50mm – 350mm
	Min – Max Width	40mm – 400mm
	Min – Max Thickness	0.6mm – 3.2mm
Tek-BC-20C Clean & By-Pass	Min – Max Length	50mm – 350mm
	Min – Max Width	40mm – 400mm
	Min – Max Thickness	0.6mm – 3.2mm
Tek-BC-20C Board Hold	N/A	N/A

WORLD LEADER IN CONTACT CLEANING

 **Teknek Head Office**
River Drive
Inchinnan Business Park
Renfrewshire, PA4 9RT
Scotland, UK

T: +44 (0)141 568 8100
E: teknek@teknek.com

 **Teknek China Ltd**
Unit E, 4/F,
Winfield Industrial Building,
3 Kin Kwan Street,
Tuen Mun, N.T.
Hong Kong

T: +852 2468 3160
E: hk@teknek.com

 **Teknek (BRUX Japan)**
1-3-1-6F Hakataekiminami
Hakata-ku,
Fukuoka-city, 812-0016
Japan

T: +81 (0)92 473 6455
E: teknekjapan@brux.jp

 **Teknek (Simco-Ion)**
2257 North Penn Road
Hatfield,
PA 19440
USA

T: +1 215 822 6401
E: ussales@teknek.com